

Conventional Sounder Strobe IP66

BANSHEE EXCEL LITE IP66(BEL-SBDB(RED))



Features

- Robust design
- Deep Base Provides IP66 Protection
- Low current consumption
- Easy to install
- Xenon beacon technology
- Maximum 110 dB(A) at 1 m (dependent on tone selected)
- 32 User Selectable Tones and 3 User Volumes

Description

The new Banshee Excel Lite™ combines the aesthetics of the Excel Sounder with the very latest strobe technology to create an extremely efficient Xenon Sounder/ Beacon combination.

The unit has the option of independent or combined operation. The Banshee Excel Lite utilises the same easy push and twist bayonet fixing as the Banshee Excel and the original MT Banshee.

Specification

Termination:	1 x 8 way terminal block. Screw terminals for 0.28mm ² to 2.5mm ² wire conductor
EN54-3 Voltage Range:	24VDC (20VDC to 28VDC)
Operating Voltage Range:	9VDC to 30VDC*
Tone Current Consumption:	See Sound output table
Tone Synchronisation:	Synchronised start
Flash Rate:	1/Sec
Flash Current Consumption:	90mA @ 12VDC 40mA @ 24VDC
Operating Temperature:	-20°C to +55°C
Case Material:	ABS
Environment Category:	Type A
IP Rating:*	Shallow Base IP45 Deep Base IP66

Units meet minimum requirements of IP21C Shallow Base & IP33C Deepbase in accordance with EN54-3

Installation

All installation to be carried out by a competent person

IP66 Deep Base Moulding (weatherproof).

- To maintain IP rating when using a Deep Base, use wall mounting bracket Part Number: MM08728. Do not drill fixing holes in deep base. Use suitably rated 20mm cable glands to fit cables or conduit via side knock-outs. Fit 'O'-Ring seal between lens and base.

Non-IP66 Deep Base.

- Knock out the conduit/cable gland holes in side of deep base.
- Fit conduit or 20mm cable glands then screw the base to the mounting surface or BESA box.

Shallow Base Moulding.

- Drill mounting holes in the bottom of Base for screw fixings.
- Route cable through rear hole or side knock-outs.
- Screw the base to the mounting surface or BESA box.

All fixings.

- Connect unit as shown in connection diagram (Left). Note: If independent supplies are required for the sounder and the beacon elements, remove LK1 and LK2.
- Place the Excel Lite onto the base and turn clockwise to retain.
- To remove the Excel Lite turn unit counter-clockwise.
- Where applicable, fit the security screw through the hole in the side of the lens assembly.

Connection diagram

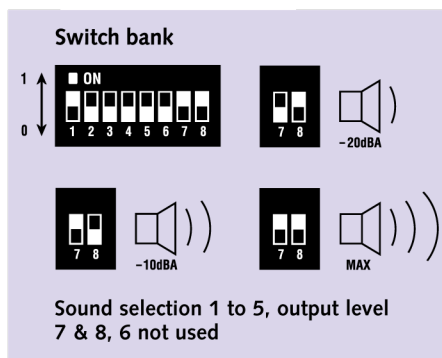
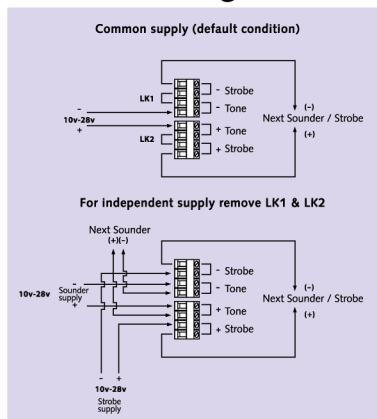

Deep base with IP66 mounting accessory

Shallow base